

PART NUMBER

**SSR-301-40-2/47-2**



**BEFORE YOU BEGIN**

**PRIMARY APPLICATIONS**

- > Dodge RAM 2500 4 X 2 (2003 - 2010)
- > Dodge RAM 2500 4 X 4 (2003 - 2010)
- > Dodge RAM 3500 4 X 2 (2003 - 2010)
- > Dodge RAM 3500 4 X 4 (2003 - 2010)
- > RAM 2500 4 X 2 (2011 - 2013)
- > RAM 2500 4 X 4 (2011 - 2013)
- > RAM 3500 4 X 2 (2011 - 2021)
- > RAM 3500 4 X 4 (2011 - present)

**TOOLS REQUIRED**

- > Floor Jack
- > Jack Stands
- > Wheel Chocks
- > 9/16" Wrench

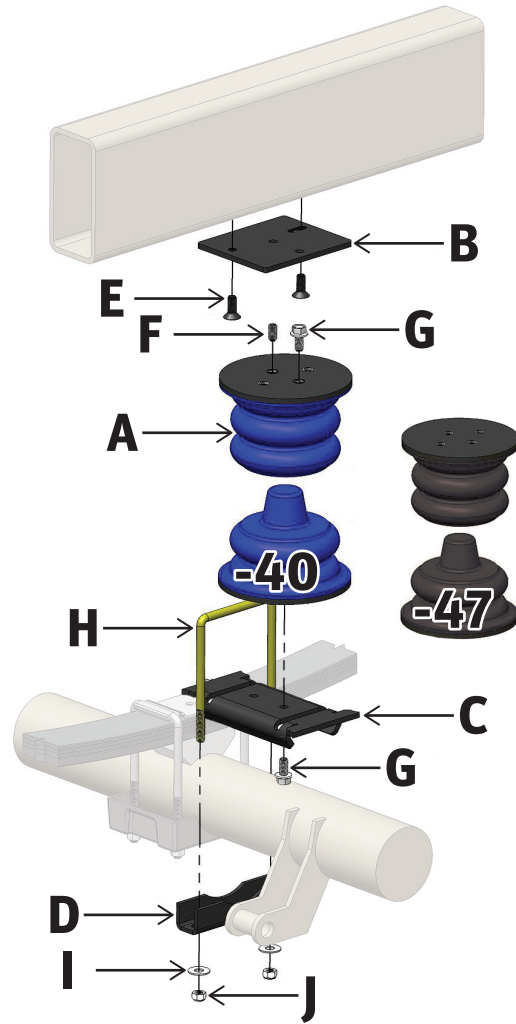

**PARTS LIST**

Item	Part #	Description	QTY
A	511419	SumoSprings Blue -40-2	2
	511418	SumoSprings Black -47-2	
B	512018	Upper Bracket Driver	2
C	512019	Lower Bracket	2
D	512021	Bail-Clamp Bracket	2
E	512238	M10 x 25MM FHCS	4
F	512263	3/8-16 x 3/4" Setscrew	2
G	512207	3/8-16 x 3/4" Serrated Flange Hex Bolt	4
H	512230	Bail-Clamp (U-Bolt)	2
I	512227	3/8 Flat Washer	4
J	512234	3/8-16 Top-Lock Nut	4

**DRIVER SIDE (PASSENGER SIDE SIMILAR)**

**Part Number: SSR-301-40-2/47-2**

**Product Line: SUMOSPRINGS REAR**

**Page 1**

Questions or Concerns?

Scan here:



or visit:  
[superspringsinternational.com](http://superspringsinternational.com)

**SAFETY NOTICE:** We recommend installation be done by a professional or persons with sound mechanical knowledge.

**WARNING:** These instructions are a general guide for installation. SuperSprings International (SSI) assumes no liability for the actual installation process. Consumers and installers should apply common automotive safety practices when raising and working on any vehicle. **Do not put yourself in a position where, if the vehicle were to move unexpectedly, you may be injured.** SSI's products are designed to improve vehicle ride quality. Do not load any vehicle beyond the manufacturer's specifications.

Never exceed the manufacturer's Gross Vehicle Rating (GVWR) located on your vehicles identification tag.

**BEFORE INSTALLATION:** Ensure the vehicle is on a hard level surface, the parking brake is ON, with the ignition OFF, and place chocks in front of and behind the tires to prevent the vehicle from moving.

**DURING AND/OR AFTER INSTALLATION:** Ensure emergency brake cables are not touching the SSI products. Secure any cables out of the way with zip ties or by re-routing. Ensure all A/C lines, brake cables, and frame are clear of contact or interference.

REV. 2.01 | JUN 2023

PART NUMBER

**SSR-301-40-2/47-2**



**INSTALLATION**

1. Park vehicle on level hard surface. Place wheel chocks in front and behind the front wheels to prevent rolling. Observe all safety precautions and wear safety glasses.
2. Raise the rear of the vehicle allowing the axle to hang free and rest the frame on the safety jack stands rated for the vehicle. Removal of the rear wheels is optional.
3. Starting on the driver side, remove the factory bump stop from the underside of the frame.
4. Remove the pre-assembled SumoSPring [ITEM A] Upper Bracket assembly [ITEM B] and a Lower Bracket assembly [ITEM C] from the box. Based on the Lower Bracket Orientation diagram confirm the orientation to achieve a snug fit between factory u-bolts and spring-pack by tilt and twist action. Please note that the Diesel truck utilizes the wider locking tabs and the Gas truck utilizes the narrower locking tabs. You may need to detach the lower bracket assembly to achieve this then re-attach the lower bracket [ITEM C] to the underside of the SumoSPring lower half using the 3/8-16 x 3/4" Serrated Flange Bolt [ITEM G] and utilizing the mounting hole as indicated above and tighten all bolts.

5. Taking up the upper bracket assembly detach plate bracket [ITEM B] from the SumoSPring Rebel upper by removing the 3/8-16 x 3/4" serrated flange bolt. Then attach upper bracket to the underside of the frame using two M10 x 25mm FHCS [ITEM E] using the same apertures from which the bump-stop was removed. Then re-attach the upper SumoSPring Rebel as before utilizing the 3/8-16 x 3/4" Setscrew [ITEM F] for location and the same 3/8-16 x 3/4" serrated flange bolt.

6. Place the lower assembly on the driver side axle housing in a tilt and twist action so as to snugly engage the bottom bracket (as marked in step 4) between the factory u-bolts and the factory spring-pack (see Lower Bracket Orientation diagram).

7. Place the Bail-Clamp (U-Bolt) [ITEM H] in the slot in lower bracket closest to the wheel. Attach the Bail-Clamp Bracket [ITEM D] under the axle to the u-bolt using 3/8-16 Top-Lock Nuts [ITEM J] and 3/8 Flat Washers [ITEM I] and secure tightly.

8. Re-tighten all bolts.

9. Repeat steps 3 through 8 on the passenger side of the vehicle.

10. If rear wheels were removed you can now reinstall the rear wheels. Jack up vehicle, remove safety jack stands and carefully lower the vehicle to the hard surface. Remove wheel chocks from the front wheels.

11. Register the warranty for your SuperSprings International part. A warranty card can be found in the box your part came in.

**LOWER BRACKET ORIENTATION**

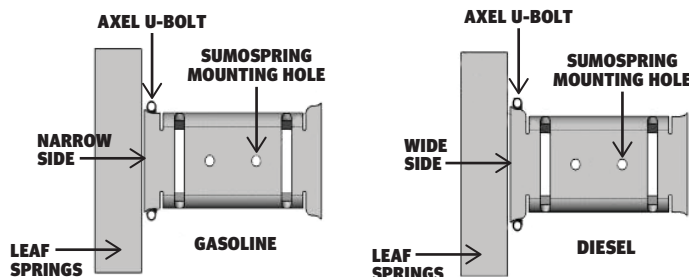

**Part Number: SSR-301-40-2/47-2**

**Product Line: SUMOSPRINGS REAR**

**Page 2**

Questions or Concerns?

Scan here:



or visit:  
[superspringsinternational.com](http://superspringsinternational.com)

**SAFETY NOTICE:** We recommend installation be done by a professional or persons with sound mechanical knowledge.

**WARNING:** These instructions are a general guide for installation. SuperSprings International (SSI) assumes no liability for the actual installation process. Consumers and installers should apply common automotive safety practices when raising and working on any vehicle. **Do not put yourself in a position where, if the vehicle were to move unexpectedly, you may be injured.** SSI's products are designed to improve vehicle ride quality. Do not load any vehicle beyond the manufacturer's specifications.

**Never exceed the manufacturer's Gross Vehicle Rating (GVWR) located on your vehicles identification tag.**

**BEFORE INSTALLATION:** Ensure the vehicle is on a hard level surface, the parking brake is ON, with the ignition OFF, and place chocks in front of and behind the tires to prevent the vehicle from moving.

**DURING AND/OR AFTER INSTALLATION:** Ensure emergency brake cables are not touching the SSI products. Secure any cables out of the way with zip ties or by re-routing. Ensure all A/C lines, brake cables, and frame are clear of contact or interference.

REV. 2.01 | JUN 2023