

PART NUMBER

SSR-147-40-2



BEFORE YOU BEGIN

PRIMARY APPLICATIONS

- > Ford F150 4 X 4 * **
(2019 - present)
- > Ford F150 4 X 2 **
(2019 - present)

* Will not work on Raptor models.
** Will not work on models with self adjusting headlights.

TOOLS REQUIRED

- > Floor jack
- > Safety jack stands
- > Standard & Metric sockets/wrenches
- > Ratchet
- > Torque wrench

PARTS LIST

Item	Part #	Description	QTY
A	511419	SumoSpring Blue -40	2
B	512180	Driver Side Upper Bracket	1
	512181	Passenger Side Upper Bracket	1
C	512165	SumoSprings Upper Bracket	2
D	512178	Driver Side Lower Bracket	1
	512179	Passenger Side Lower Bracket	1
E	512168	3/8 Tag Nut	4
F	112185	U-Cross Plate	4
G	512248	3/8 Fender Washer	4
H	512207	3/8-16 X 3/4" Flange Bolt	6
I	512278	3/8-16 X 1-1/4" Flange Bolt	12
J	512302	3/8 Locking Flange Nut	16
K	512373	3/8-16 X 3" Carriage Bolt	8
L	512312	M10-1.5 X 30MM Flange Bolt	2

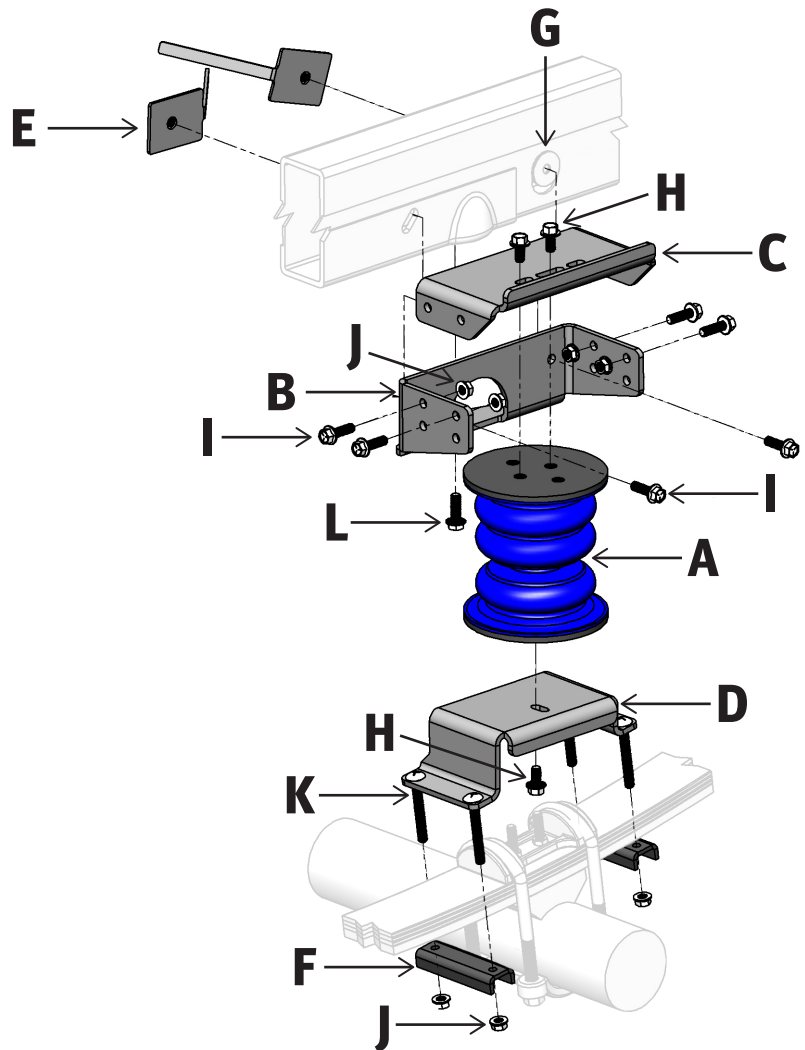

DRIVER SIDE (PASSENGER SIDE SIMILAR)

Part Number: SSR-147-40-2

Product Line: SUMOSPRINGS

Page 1

Questions or Concerns?

Scan here:



or visit:
superspringsinternational.com

SAFETY NOTICE: We recommend installation be done by a professional or persons with sound mechanical knowledge.

WARNING: These instructions are a general guide for installation. SuperSprings International (SSI) assumes no liability for the actual installation process. Consumers and installers should apply common automotive safety practices when raising and working on any vehicle. **Do not put yourself in a position where, if the vehicle were to move unexpectedly, you may be injured.** SSI's products are designed to improve vehicle ride quality. Do not load any vehicle beyond the manufacturer's specifications.

Never exceed the manufacturer's Gross Vehicle Rating (GVWR) located on your vehicles identification tag.

BEFORE INSTALLATION: Ensure the vehicle is on a hard level surface, the parking brake is ON, with the ignition OFF, and place chocks in front of and behind the tires to prevent the vehicle from moving.

DURING AND/OR AFTER INSTALLATION: Ensure emergency brake cables are not touching the SSI products. Secure any cables out of the way with zip ties or by re-routing. Ensure all A/C lines, brake cables, and frame are clear of contact or interference.

REV. 1.01 | SEP 2023

PART NUMBER

SSR-147-40-2



INSTALLATION

1. Park vehicle on a hard, level surface. Place wheel chocks in front and behind the front wheels to prevent rolling. Observe all safety precautions and wear safety glasses.
2. Raise the rear of the vehicle allowing the axle to hang free and rest the frame on the safety jack stands. Removal of the rear wheels is optional.
3. Starting on the driver side, remove the factory bump stop from the underside of the frame.
4. Find two of the 3/8 Tag Nuts [ITEM E] and bend the tangs up at about a 45 degree angle. Place them through the oval hole on the inside of the frame rail.
5. Find Driver Side Upper Bracket [ITEM B]. Attach it to the bottom of the frame rail using the M10-1.5 x 30mm Flange Bolt [ITEM L] but leave it loose for now.
6. Place two of the 3/8 Fender Washers [ITEM G] behind the rear hole of the Upper Bracket. **NOTE:** If frame reinforcement is present around rear hole, Fender Washers are not needed.
7. Insert one 3/8 x 1 1/2" Flange bolt [ITEM I] through the rear hole of the bracket, through the two fender washers, and through the large hole in the frame. Thread the bolt into the 3/8 Tag Nut [ITEM E] and fasten finger tight.
8. Insert one 3/8 x 1 1/2" Flange bolt [ITEM I] through the front hole of the bracket and through the hole in the frame. Thread the bolt into the 3/8 Tag Nut [ITEM E] and fasten finger tight.
9. Torque the two 3/8 bolts and one M10 bolt to 25 ft. lbs.
10. Find the SumoSpring Upper Bracket [ITEM C] and fasten to the top half of the SumoSpring [ITEM A] using two 3/8 x 3/4" Flange Bolts [ITEM H] through the forward two slots in the bracket as seen in the diagram. Tighten finger tight only.
11. Attach the SumoSpring Upper Bracket [ITEM C] to Driver Side Upper Bracket [ITEM B] using four 3/8 x 1 1/2" Flange Bolts [ITEM I] and 3/8 Flange nuts [ITEM J]. Use the upper set of holes for a 2wd and the lower set of holes for a 4wd as seen in the diagram. Torque bolts/nuts to 25 ft. lbs.
12. Find Driver Side Lower Bracket [ITEM D] and attach it to the bottom half of the SumoSpring [ITEM A] with one 3/8 x 3/4" Flange Bolt [ITEM H]. Leave bolt finger tight for now.
13. Place the Driver Side Lower Bracket [ITEM D] on top of the factory leaf springs, straddling the factory top plate as seen in the diagram. Attach to the leaf pack using four 3/8-16 x 3" Carriage Bolts [ITEM K], two U-Cross Plates [ITEM F], and four Flange nuts [ITEM J], leave loose for now.
14. Repeat steps 3 through 13 on the passenger side.
15. Once both sides are to this point, use a jack to raise the axle so the upper and lower halves of the SumoSprings are close to touching.
16. Using the adjustment slots, align the top and bottom halves of the SumoSprings.
17. Once both sides are aligned, tighten the Carriage Bolt nuts [ITEM J] securely, be careful not to bend the brackets.
18. Torque the rest of the hardware to 25 ft. lbs.
19. If rear wheels were removed you can now reinstall the rear wheels and torque wheel nuts to manufacturers spec.
20. Jack up vehicle, remove safety jack stands. Remove wheel chocks from the front wheels.
21. Register the warranty for your SuperSprings International part. A warranty card can be found in the box your part came in.

Part Number: SSR-147-40-2

Product Line: SUMOSPRINGS

Page 2

Questions or Concerns?

Scan here:



or visit:
superspringsinternational.com

SAFETY NOTICE: We recommend installation be done by a professional or persons with sound mechanical knowledge.

WARNING: These instructions are a general guide for installation. SuperSprings International (SSI) assumes no liability for the actual installation process. Consumers and installers should apply common automotive safety practices when raising and working on any vehicle. **Do not put yourself in a position where, if the vehicle were to move unexpectedly, you may be injured.** SSI's products are designed to improve vehicle ride quality. Do not load any vehicle beyond the manufacturer's specifications.

Never exceed the manufacturer's Gross Vehicle Rating (GVWR) located on your vehicles identification tag.

BEFORE INSTALLATION: Ensure the vehicle is on a hard level surface, the parking brake is ON, with the ignition OFF, and place chocks in front of and behind the tires to prevent the vehicle from moving.

DURING AND/OR AFTER INSTALLATION: Ensure emergency brake cables are not touching the SSI products. Secure any cables out of the way with zip ties or by re-routing. Ensure all A/C lines, brake cables, and frame are clear of contact or interference.

REV. 1.01 | SEP 2023