

PART NUMBER
SSA20



BEFORE YOU BEGIN

TOOLS REQUIRED

- > Floor Jack
- > Safety Jack Stands
- > Wheel Chocks
- > ¾" Wrench & Socket
- > Heavy Duty Clamps or SuperSprings Installation Tool

PRIMARY APPLICATIONS

- > Nissan Titan 4 X 2 (2004 - 2015)
- > Nissan Titan 4 X 4 (2004 - 2015)

PARTS LIST

Item	Part #	Description	QTY
A	102009	SSA20 SuperSpring	2
B	112129	Steel Sleeve	4
C	112189	HDPE Roller	4
D	122400	Angled Shackle	4
E	112124	½-13 x 2 ¾" Hex Bolt	4
F	112125	½-13 x 4 ½" Hex Bolt	4
G	112126	½-13 Nylock Nut	8
H	112127	½" Nylon Flat Washer	16
I	122402	Square Shackle	4
J	112140	Polyurethane Bushing	8
K	311003	Bump Stop	2
L	PSP-8	Polyurethane Spring Pad	2
M	112271	Clamp Plate	2
N	512266	½-13 x 1 ¾" Hex Bolt	4
O	112130	½" Flat Washer	4
P	112164	½-13 Top Lock Nut	4

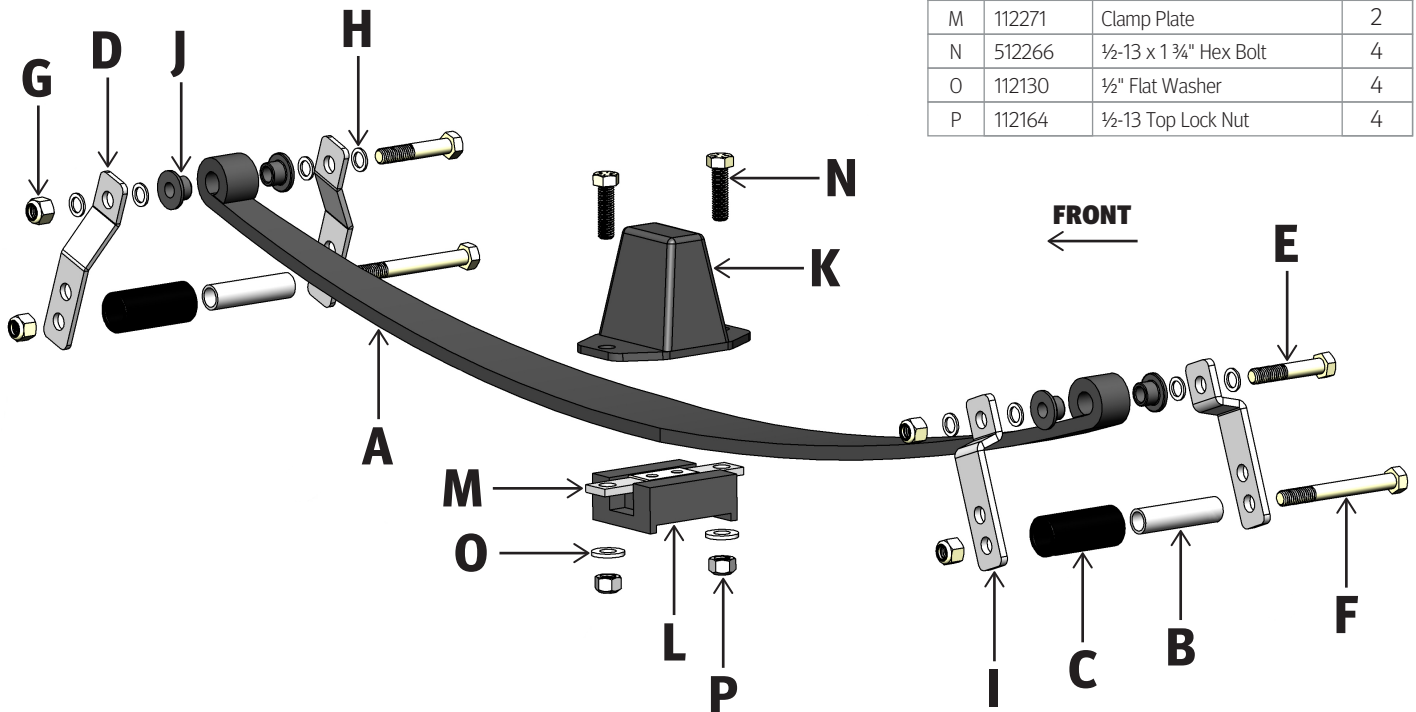

Part Number: SSA20

Product Line: SUPERSPRINGS

Page 1

Questions or Concerns?

Scan here:



or visit:
superspringsinternational.com

SAFETY NOTICE: We recommend installation be done by a professional or persons with sound mechanical knowledge.

WARNING: These instructions are a general guide for installation. SuperSprings International (SSI) assumes no liability for the actual installation process. Consumers and installers should apply common automotive safety practices when raising and working on any vehicle. **Do not put yourself in a position where, if the vehicle were to move unexpectedly, you may be injured.** SSI's products are designed to improve vehicle ride quality. Do not load any vehicle beyond the manufacturer's specifications.

Never exceed the manufacturer's Gross Vehicle Rating (GVWR) located on your vehicles identification tag.

BEFORE INSTALLATION: Ensure the vehicle is on a hard level surface, the parking brake is ON, with the ignition OFF, and place chocks in front of and behind the tires to prevent the vehicle from moving.

DURING AND/OR AFTER INSTALLATION: Ensure emergency brake cables are not touching the SSI products. Secure any cables out of the way with zip ties or by re-routing. Ensure all A/C lines, brake cables, and frame are clear of contact or interference.

REV. 2.01 | OCT 2023

PART NUMBER
SSA20



INSTALLATION

1. Positioning the vehicle – Vehicle must be on level solid surface. Ensure emergency brake is ON, Ignition is OFF. Place blocks in front and rear of the front tires to prevent the vehicle moving. With the vehicle still on the ground (one side at a time), loosen axle u-bolts to allow removal of the factory bump-stop. Retighten u-bolts as per Toyota's specifications.

Important: After 500 miles of driving retighten u-bolts again.

2. Jack up vehicle – Raise the vehicle so that rear wheels are slightly off the ground. Place jack stands under the frame. You may remove the wheel for easier installation access but this is optional.

3. The SSA20 has a specific left and right, and front and back. The Angled Shackle [ITEM D] must go to the front and the Square Shackle [ITEM I] to the rear. Also, the threads of the spring eye and roller bolts must face out, away from the frame.

4. Remove Shackle Roller Assemblies – Using ¾" tools, wrenches / sockets / ratchet, remove and set aside the bolts [ITEM F] and nuts [ITEM G] retaining the Rollers [ITEM C] and Sleeves [ITEM B] from the front and rear of the shackles. Rotate the Shackles [ITEM D & I] toward the center and parallel to the spring.

5. Starting on the driver side, insert the Clamp Plate [ITEM M] into the steel channel of the PSP-8 [ITEM L] so that it is centered. Attach the PSP-8 [ITEM L] to the bottom and the Bump Stop [ITEM K] on the top of the SSA20 using the ½-13 x 1 ¾" Hex Bolt [ITEM N], Flat Washer [ITEM O], and Lock Nut [ITEM P] leaving the hardware loose for now.

6. Position the assembly on top of the factory springs with the PSP-8 located between the u-bolts where the factory bump stop was removed. Be sure that the shorter shackle is to the rear and the threads of the eye bolts are facing out, away from the frame. Slide the SuperSpring front to rear to find the position with the greatest clearance, the spring does not need to be centered on the PSP.

Part Number: SSA20

Product Line: SUPERSPRINGS

Page 2

Questions or Concerns?

Scan here:



or visit:
superspringsinternational.com

SAFETY NOTICE: We recommend installation be done by a professional or persons with sound mechanical knowledge.

WARNING: These instructions are a general guide for installation. SuperSprings International (SSI) assumes no liability for the actual installation process. Consumers and installers should apply common automotive safety practices when raising and working on any vehicle. **Do not put yourself in a position where, if the vehicle were to move unexpectedly, you may be injured.** SSI's products are designed to improve vehicle ride quality. Do not load any vehicle beyond the manufacturer's specifications.

Never exceed the manufacturer's Gross Vehicle Rating (GVWR) located on your vehicles identification tag.

BEFORE INSTALLATION: Ensure the vehicle is on a hard level surface, the parking brake is ON, with the ignition OFF, and place chocks in front of and behind the tires to prevent the vehicle from moving.

DURING AND/OR AFTER INSTALLATION: Ensure emergency brake cables are not touching the SSI products. Secure any cables out of the way with zip ties or by re-routing. Ensure all A/C lines, brake cables, and frame are clear of contact or interference.

REV. 2.01 | OCT 2023

PART NUMBER
SSA20



INSTALLATION

7. Shackle Attachment – Note: The top/spring eye shackle bolts are factory pre-torqued; no adjustment or further tightening is needed. If any are loosened by the installer then re-torque to 25 ft. lbs.

Shackle Attachment Front – Rotate the front shackles [ITEM D] legs down on both sides of the leaf spring. Using ITL-1 or other high capacity clamp(s), compress the SuperSprings and factory leaf pack together. Place the Sleeve [ITEM B] and the Roller [ITEM C] between the Shackle Legs and align with desired preload holes. Secure with ½-13 x 4 ½" Hex Bolt [ITEM F] and ½-13 Lock Nut [ITEM G]. Torque to 30 ft. lbs. Ensure there is clearance on all sides of the shackle.

Shackle Attachment Rear – Rotate the rear shackles [ITEM I] legs down on both sides of the leaf spring. Using ITL-1 or other high capacity clamp(s), compress the SuperSprings and factory leaf pack together. Place the Sleeve [ITEM B] and the Roller [ITEM C] between the Shackle Legs and align with desired preload holes. Secure with ½-13 x 4 ½" Hex Bolt [ITEM F] and ½-13 Lock Nut [ITEM G]. Torque to 30 ft. lbs. Ensure there is clearance on all sides of the shackle.

8. Once the shackles are installed, tighten the hardware securing the Bump Stop [ITEM K] in place.

9. Repeat steps 3 through 8 on the passenger side.

10. Lower the vehicle – elevate chassis, remove the jack stands, lower to the ground. Remove wheel chocks from front wheels.

11. Final Check – Check the position of the SuperSprings ensuring for correct hardware application and orientation. Observe all hardware ensuring for static and dynamic interference clearances. Recheck all hardware to ensure it is securely tightened.

NOTE: After 200-500 miles of driving, recheck all hardware again for tightness.

12. Register the warranty for your SuperSprings International part. A warranty card can be found in the box your part came in.

Part Number: SSA20

Product Line: SUPERSPRINGS

Page 3

Questions or Concerns?

Scan here:



or visit:
superspringsinternational.com

SAFETY NOTICE: We recommend installation be done by a professional or persons with sound mechanical knowledge.

WARNING: These instructions are a general guide for installation. SuperSprings International (SSI) assumes no liability for the actual installation process. Consumers and installers should apply common automotive safety practices when raising and working on any vehicle. **Do not put yourself in a position where, if the vehicle were to move unexpectedly, you may be injured.** SSI's products are designed to improve vehicle ride quality. Do not load any vehicle beyond the manufacturer's specifications.

Never exceed the manufacturer's Gross Vehicle Rating (GVWR) located on your vehicles identification tag.

BEFORE INSTALLATION: Ensure the vehicle is on a hard level surface, the parking brake is ON, with the ignition OFF, and place chocks in front of and behind the tires to prevent the vehicle from moving.

DURING AND/OR AFTER INSTALLATION: Ensure emergency brake cables are not touching the SSI products. Secure any cables out of the way with zip ties or by re-routing. Ensure all A/C lines, brake cables, and frame are clear of contact or interference.

REV. 2.01 | OCT 2023