

PART NUMBER  
**MXKT**



**BEFORE YOU BEGIN**

**TOOLS REQUIRED**

- › Floor Jack
- › Safety Jack Stands
- › Wheel Chocks
- › ¾" Wrench/Socket
- › ½" Wrench/Socket

**PRIMARY APPLICATIONS**

- › Used for installation of SuperSprings Kits for various applications

**PARTS LIST - STANDARD INSTALLATION**

Item	Part #	Description	QTY
A	112211	MTKT W-Bracket	2
B	112219	Square U-Bolt	4
C	112203	Mounting Kit Cross Plate	4
D	112130	½" Flat Washer	8
E	112126	½-13 Nylock Nut	8
F	112282	Hold Down Plate	4
G	112208	5/16-18 Nylock Nut	4
H	112215	5/16-18 x 2-½" Hex Bolt	4
I	512244	5/16 Flat Washer	8

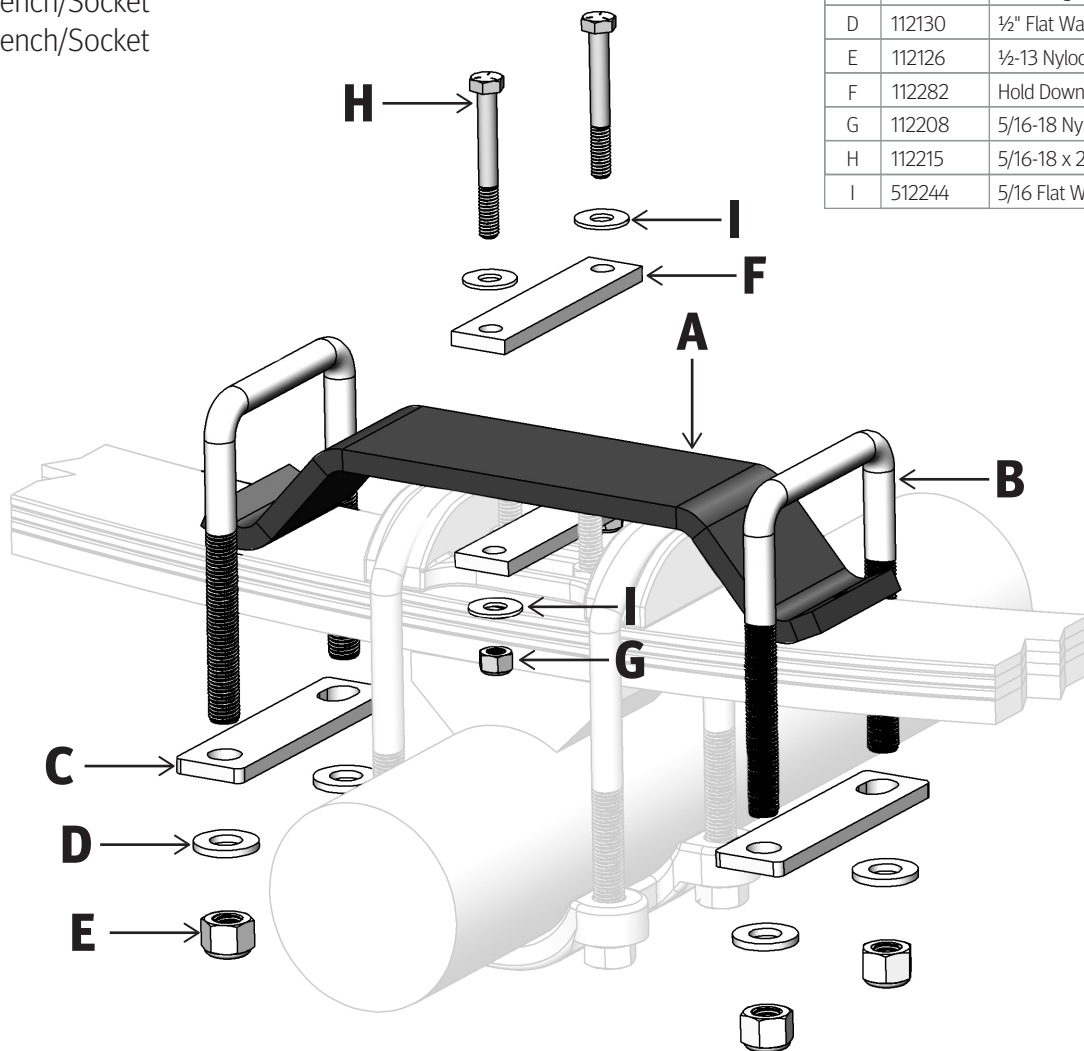

**Part Number: MXKT**

**Product Line: MOUNTING KITS**

**Page 1**

Questions or Concerns?

Scan here:



or visit:  
superspringsinternational.com

**SAFETY NOTICE:** We recommend installation be done by a professional or persons with sound mechanical knowledge.

**WARNING:** These instructions are a general guide for installation. SuperSprings International (SSI) assumes no liability for the actual installation process. Consumers and installers should apply common automotive safety practices when raising and working on any vehicle. **Do not put yourself in a position where, if the vehicle were to move unexpectedly, you may be injured.** SSI's products are designed to improve vehicle ride quality. Do not load any vehicle beyond the manufacturer's specifications.

Never exceed the manufacturer's Gross Vehicle Rating (GVWR) located on your vehicles identification tag.

**BEFORE INSTALLATION:** Ensure the vehicle is on a hard level surface, the parking brake is ON, with the ignition OFF, and place chocks in front of and behind the tires to prevent the vehicle from moving.

**DURING AND/OR AFTER INSTALLATION:** Ensure emergency brake cables are not touching the SSI products. Secure any cables out of the way with zip ties or by re-routing. Ensure all A/C lines, brake cables, and frame are clear of contact or interference.

PART NUMBER

**MXKT**



**INSTALLATION**

1. Positioning the vehicle – Vehicle must be on level solid surface. Ensure emergency brake is ON and Ignition is OFF. Chock both front and rear of the front tires to prevent the vehicle from moving.
2. Jack up vehicle – elevate and support the frame securing with jack stands so that the axle is hanging with tires slightly off the ground. Wheel removal is suggested ONLY were bodies are mounted.
3. Place W-Bracket [ITEM A] on top of factory leaf springs directly above the axle, straddling the factory spring plate.
4. Using the Square U-bolts [ITEM B], Cross Plates [ITEM C], ½" Flat Washers [ITEM D], and ½" Nylock Nuts [ITEM E], fasten the W-Bracket to the leaf springs as in the diagram.
5. Install the SuperSprings on top of the W-Bracket (see instructions included with SuperSprings).
6. Secure the SuperSprings to the W-Bracket using the Hold Down Plates [ITEM F], 5/16" Bolts [ITEM H], 5/16" Flat Washers [ITEM I], and 5/16" Nylock Nuts [ITEM G].
7. Securely retighten all hardware after 200-500 miles of driving.

**Part Number: MXKT**

**Product Line: MOUNTING KITS**

**Page 2**

Questions or Concerns?

Scan here:



or visit:  
[superspringsinternational.com](http://superspringsinternational.com)

**SAFETY NOTICE:** We recommend installation be done by a professional or persons with sound mechanical knowledge.

**WARNING:** These instructions are a general guide for installation. SuperSprings International (SSI) assumes no liability for the actual installation process. Consumers and installers should apply common automotive safety practices when raising and working on any vehicle. **Do not put yourself in a position where, if the vehicle were to move unexpectedly, you may be injured.** SSI's products are designed to improve vehicle ride quality. Do not load any vehicle beyond the manufacturer's specifications.

**Never exceed the manufacturer's Gross Vehicle Rating (GVWR) located on your vehicles identification tag.**

**BEFORE INSTALLATION:** Ensure the vehicle is on a hard level surface, the parking brake is ON, with the ignition OFF, and place chocks in front of and behind the tires to prevent the vehicle from moving.

**DURING AND/OR AFTER INSTALLATION:** Ensure emergency brake cables are not touching the SSI products. Secure any cables out of the way with zip ties or by re-routing. Ensure all A/C lines, brake cables, and frame are clear of contact or interference.

REV. 2.01 | AUG 2023