

SuperSprings Shackle Options

All SuperSprings applications are length specific to best fit the dimensions of your vehicles spring pack. The shackles attached to the eyes at each end of the SuperSprings have multiple bolt-hole options allowing some preload tension adjustment. The “longer” the shackle – when the lower bolt holes are used – the less the amount of preload tension on the SuperSprings and the least noticeable impact on the unloaded vehicles ride quality and ride height.

The “shorter” the shackle – when the upper bolt holes are used – more preload tension is induced on the SuperSprings and the greater the change on the unloaded vehicle ride quality and ride height. The combination of upper and lower bolt holes being used on opposite ends of the SuperSpring creates intermediate ride quality and ride height results.

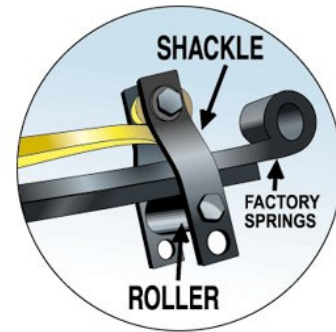

“Short” or single-hole shackles are generally used in applications where clearance between the top of the SuperSpring and the vehicle frame needs to be increased. Using the upper (top) bolt hole on a two or three-hole shackle will produce the same effect. (See image above)

A “square” shackle is used on some applications that are equipped with a stock above-spring factory overload. In these cases the square SuperSprings shackle “captures” the end of the factory overload spring. (See SSA16 installation instructions for the Ford F250/350 with factory overload for more specific details.)

Shown below are images of some of the shackles used on various SuperSpring models:



Please call our toll-free tech support line @ 866-898-0720 with any questions you have.