

PART NUMBER

SSF-106-40/47



SCAN HERE: To watch a video of this installation



BEFORE YOU BEGIN

PRIMARY APPLICATIONS

- > Dodge Sprinter 2500 & 3500 4 X 2 (2007 - 2009)
- > Ford E-150 4 X 2 (2002 - 2014)
- > Ford E-150 Club Wagon 4 X 2 (2003 - 2005)
- > Ford E-150 Econoline 4 X 2 (1975 - 2002) & (2007 - 2008)
- > Ford E-150 Econoline Club Wagon 4 X 2 (1975 - 2002)
- > Ford E-250 4 X 2 (2003 - 2014)
- > Ford E-250 Econoline 4 X 2 (1975 - 2002)
- > Ford E-250 Econoline Club Wagon 4 X 2 (1975 - 1991)
- > Ford E-350 Club Wagon 4 X 2 (2002 - 2005)
- > Ford E-350 Econoline 4 X 2 (1996 - 2000)
- > Ford E-350 Econoline Club Wagon 4 X 2 (1996 - 2002)
- > Ford E-350 Super Duty 4 X 2 (1999 - present)
- > Ford E-450 Econoline Super Duty 4 X 2 (1999 - 2002)
- > Ford E-450 Super Duty 4 X 2 (2003 - present)
- > Freightliner Sprinter 2500 & 3500 4 X 2 (2007 - present)
- > Mercedes-Benz Sprinter 1500 4 X 2 (2017 - present)
- > Mercedes-Benz Sprinter 2500 & 3500 4 X 2 (2010 - present)

PARTS LIST

Item	Part #	Description	QTY
A	511441	SumoSprings Blue -40	2
	511442	SumoSprings Black -47	
B	512215	M8 Washers	2
C	512219	M8 Nylock Nuts	2

TOOLS REQUIRED

- > Floor Jack
- > Jack Stands
- > Wheel Chocks
- > 10mm Socket/Wrench
- > Ratchet with extension

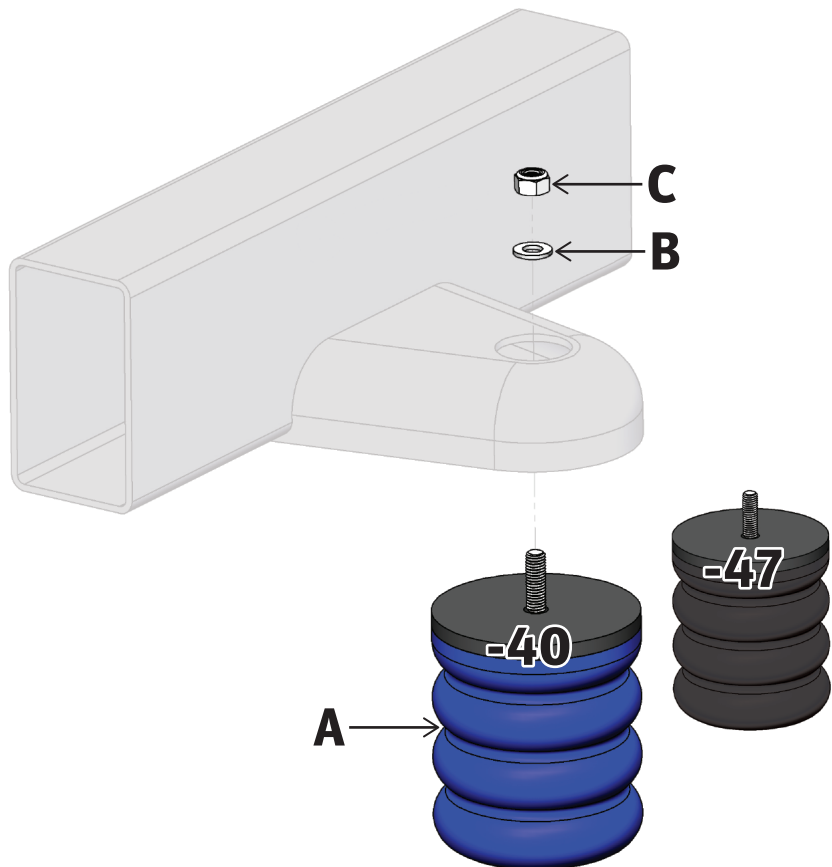

DRIVER SIDE (PASSENGER SIDE SIMILAR)

Part Number: SSF-106-40/47

Product Line: SUMOSPRINGS FRONT

Page 1

Questions or Concerns?

Scan here:



or visit:
superspringsinternational.com

SAFETY NOTICE: We recommend installation be done by a professional or persons with sound mechanical knowledge.

WARNING: These instructions are a general guide for installation. SuperSprings International (SSI) assumes no liability for the actual installation process. Consumers and installers should apply common automotive safety practices when raising and working on any vehicle. **Do not put yourself in a position where, if the vehicle were to move unexpectedly, you may be injured.** SSI's products are designed to improve vehicle ride quality. Do not load any vehicle beyond the manufacturer's specifications.

Never exceed the manufacturer's Gross Vehicle Rating (GVWR) located on your vehicles identification tag.

BEFORE INSTALLATION: Ensure the vehicle is on a hard level surface, the parking brake is ON, with the ignition OFF, and place chocks in front of and behind the tires to prevent the vehicle from moving.

DURING AND/OR AFTER INSTALLATION: Ensure emergency brake cables are not touching the SSI products. Secure any cables out of the way with zip ties or by re-routing. Ensure all A/C lines, brake cables, and frame are clear of contact or interference.

REV. 2.02 | AUG 2023

PART NUMBER

SSF-106-40/47



INSTALLATION

1. Park the vehicle on a hard, level surface and engage the emergency brake. Place chocks in front and behind wheels to prevent rolling. Observe all safety precautions and wear safety glasses.
2. Raise the front of vehicle to allow the axle to hang freely and support the frame using safety jack stands.
3. Starting on the driver side, unbolt and removing the existing bump stop from the underside of the frame.
4. Insert the stud on the end of the SumoSpring [ITEM A] into the hole where the bump stop was located.
5. Using the M8 Nylock Nuts [ITEM C] and M8 Washers [ITEM B] attach the SumoSpring [ITEM A] to the frame and tighten securely.

IMPORTANT NOTE: M8 Nylock Nuts [ITEM C] & M8 Washers [ITEM B] are not used on Ford Applications.

6. Repeat steps 3 through 5 on the passenger side of the vehicle.
7. Raise the vehicle, remove safety jack stands, and carefully lower vehicle to the hard surface. Remove the chocks in front and back of the rear wheels.
8. Register the warranty for your SuperSprings International part. A warranty card can be found in the box your part came in.

Part Number: SSF-106-40/47

Product Line: SUMOSPRINGS FRONT

Page 2

Questions or Concerns?

Scan here:



or visit:
superspringsinternational.com

SAFETY NOTICE: We recommend installation be done by a professional or persons with sound mechanical knowledge.

WARNING: These instructions are a general guide for installation. SuperSprings International (SSI) assumes no liability for the actual installation process. Consumers and installers should apply common automotive safety practices when raising and working on any vehicle. **Do not put yourself in a position where, if the vehicle were to move unexpectedly, you may be injured.** SSI's products are designed to improve vehicle ride quality. Do not load any vehicle beyond the manufacturer's specifications.

Never exceed the manufacturer's Gross Vehicle Rating (GVWR) located on your vehicles identification tag.

BEFORE INSTALLATION: Ensure the vehicle is on a hard level surface, the parking brake is ON, with the ignition OFF, and place chocks in front of and behind the tires to prevent the vehicle from moving.

DURING AND/OR AFTER INSTALLATION: Ensure emergency brake cables are not touching the SSI products. Secure any cables out of the way with zip ties or by re-routing. Ensure all A/C lines, brake cables, and frame are clear of contact or interference.

REV. 2.02 | AUG 2023

PART NUMBER

SSR-338-47/54



SCAN HERE: To watch a video of this installation



BEFORE YOU BEGIN

PRIMARY APPLICATIONS

- > Dodge Sprinter 3500 4 X 2
(2004 - 2009)
- > Freightliner Sprinter 3500 4 X 2
(2007 - present)
- > Mercedes-Benz Sprinter 3500 4 X 2
(2010 - present)
- > Mercedes-Benz Sprinter 4500 4 X 2
(2017 - present)

TOOLS REQUIRED

- > Floor Jack
- > Jack Stands
- > Wheel Chocks
- > Flat Head Screwdriver

PARTS LIST

Item	Part #	Discription	QTY
A	511459	SumoSprings Black -47	2
	511451	SumoSprings Yellow -54	

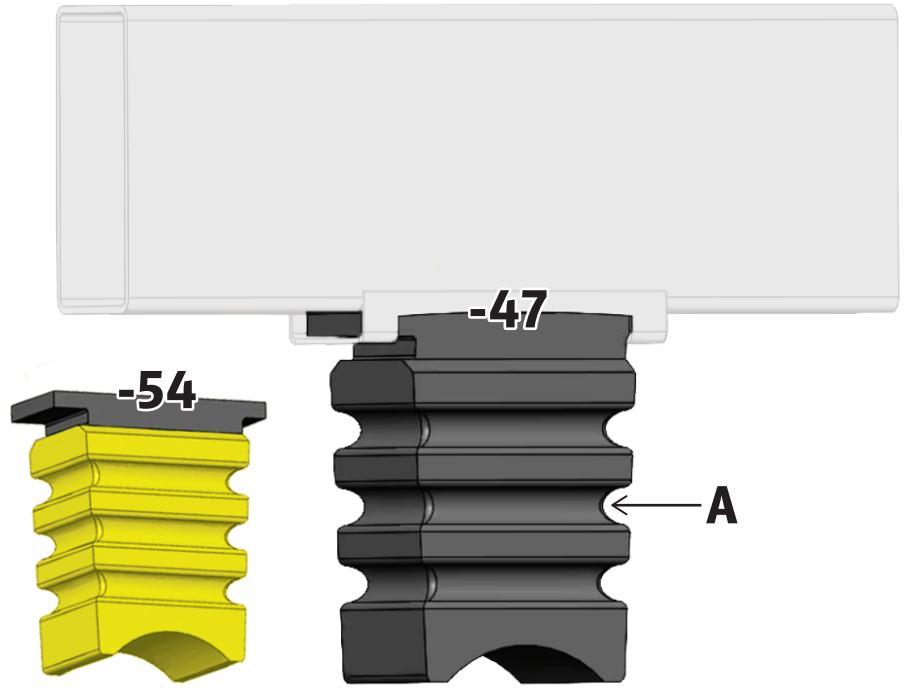

DRIVER SIDE (PASSENGER SIDE SIMILAR)

Questions or Concerns?

Scan here:



or visit:
superspringsinternational.com

SAFETY NOTICE: We recommend installation be done by a professional or persons with sound mechanical knowledge.

WARNING: These instructions are a general guide for installation. SuperSprings International (SSI) assumes no liability for the actual installation process. Consumers and installers should apply common automotive safety practices when raising and working on any vehicle. **Do not put yourself in a position where, if the vehicle were to move unexpectedly, you may be injured.** SSI's products are designed to improve vehicle ride quality. Do not load any vehicle beyond the manufacturer's specifications.

Never exceed the manufacturer's Gross Vehicle Rating (GVWR) located on your vehicles identification tag.

BEFORE INSTALLATION: Ensure the vehicle is on a hard level surface, the parking brake is ON, with the ignition OFF, and place chocks in front of and behind the tires to prevent the vehicle from moving.

DURING AND/OR AFTER INSTALLATION: Ensure emergency brake cables are not touching the SSI products. Secure any cables out of the way with zip ties or by re-routing. Ensure all A/C lines, brake cables, and frame are clear of contact or interference.

PART NUMBER

SSR-338-47/54



INSTALLATION

1. Park the vehicle on a hard, level surface and engage the emergency brake. Place chocks in front and behind wheels to prevent rolling. Observe all safety precautions and wear safety glasses.
2. Raise the rear of vehicle to allow the axle to hang freely and support the frame using safety jack stands.
3. Starting on the driver side, remove the existing factory bump stop from the underside of the frame by pulling and twisting the rubber tabs out of the frame brackets. You may need to use a flathead screwdriver to pry it out.
4. Insert the top rear tab (end with the cut-out notch) at an angle into the rear part of the frame bracket. Slide the SumoSpring [ITEM A] to the rear so the tab is seated as far back into the frame bracket as possible. Then slide the SumoSpring forward so that the front tab slides into the front frame bracket. You may also use the flat head screwdriver to push the tabs in place if needed.
5. The SumoSpring [ITEM A] should be fully seated and centered over axle looking similar to the original factory bump stop.
6. Repeat steps 3 through 5 on the passenger side of your vehicle.
7. Raise the vehicle, remove safety jack stands, and carefully lower vehicle to the hard surface. Remove the chocks in front and back of the rear wheels.
8. Register the warranty for your SuperSprings International part. A warranty card can be found in the box your part came in.

Part Number: SSR-338-47/54

Product Line: SUMOSPRINGS REAR

Page 2

Questions or Concerns?

Scan here:



or visit:
superspringsinternational.com

SAFETY NOTICE: We recommend installation be done by a professional or persons with sound mechanical knowledge.

WARNING: These instructions are a general guide for installation. SuperSprings International (SSI) assumes no liability for the actual installation process. Consumers and installers should apply common automotive safety practices when raising and working on any vehicle. **Do not put yourself in a position where, if the vehicle were to move unexpectedly, you may be injured.** SSI's products are designed to improve vehicle ride quality. Do not load any vehicle beyond the manufacturer's specifications.

Never exceed the manufacturer's Gross Vehicle Rating (GVWR) located on your vehicles identification tag.

BEFORE INSTALLATION: Ensure the vehicle is on a hard level surface, the parking brake is ON, with the ignition OFF, and place chocks in front of and behind the tires to prevent the vehicle from moving.

DURING AND/OR AFTER INSTALLATION: Ensure emergency brake cables are not touching the SSI products. Secure any cables out of the way with zip ties or by re-routing. Ensure all A/C lines, brake cables, and frame are clear of contact or interference.

REV. 2.01 | SEP 2023